



Plastic Control Valves



Globe & Angle Irrigation Valves

The series 80 valves are designed to offer the highest performance in greenhouse, field crops and turf irrigation systems. With straight or angle flow design, the 80 series valves are used for all control applications while ensuring minimal maintenance and maximal reliability.

Features and Benefits

- Simple, reliable and economical
- Angle or straight, globe-pattern valve, activated by a fully supported diaphragm
- Durable, corrosion free materials
- Unique clog-free labyrinth inlet of the activation water on electric 2-way valves
- 3 Position Manual override on electric 2-way valves
- Operation at wide range of flow rates, from near zero to the maximal flow
- Electric 2-way or hydraulic / electric 3-way actuation
- All of the control system's devices are assembled on the valve's bonnet.
- No tubes are connected to the body
- Removable flow control stem handle (optional)
- Integral stainless-steel EasyClean® filter



Technical Data

Pressure losses

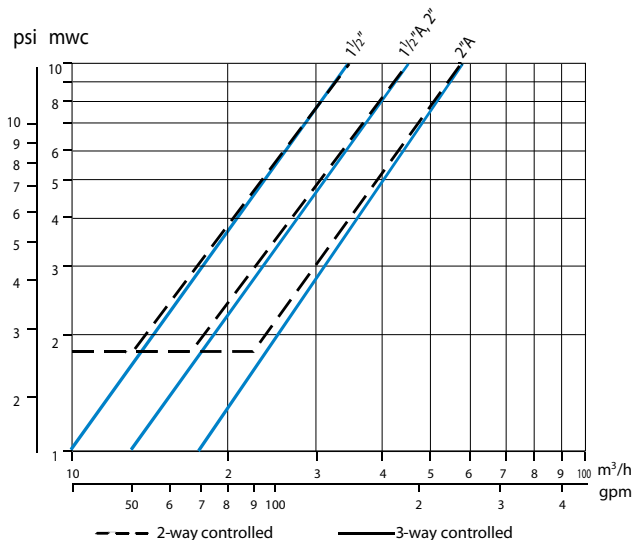

Dimensions

Dimension		40mm, 1 1/2"		50mm, 2"	
		Angle	Straight	Angle	Straight
Height (H)	mm	171	159	171	166
	inch	6.73	6.23	6.73	6.54
Length - Straight (L) Center to outlet-Angle	mm	88	165	88	165
	inch	3.46	6.5	3.46	6.5
Length	mm	163	163	163	163
	inch	6.42	6.42	6.42	6.42
Weight	kg	0.8	0.9	0.8	0.9
	lbs	1.8	2	1.8	2

Operation data

		40mm, 1 1/2"	50mm, 2"
		Max. Flow	m³/hr
	gpm	110	176
Pressure range	bar	0.5-10	
	psi	7-150	
Max. Water Temp.	°C	60	
	°F	140	
Max. Ambient Temp.	°C	52	
	°F	125	

80-1, 80-3/4" Turf Irrigation Valves

Electric valve for gardens, parks and golf courses

Features and Benefits

- Simple, reliable and economical
- Globe- pattern valve, activated by a fully- supported diaphragm
- Durable, corrosion free materials
- Unique clog- free labyrinth inlet of the activation water
- Operation at wide range of flow rates, from near zero to the maximal flow
- Internal bleed manual override opening
- Removable flow control stem handle (optional)
- No filters
- No cleaning needle

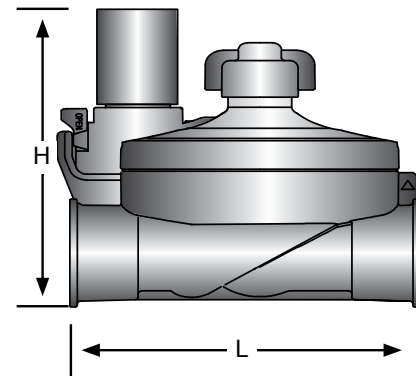

Technical Data

Pressure losses

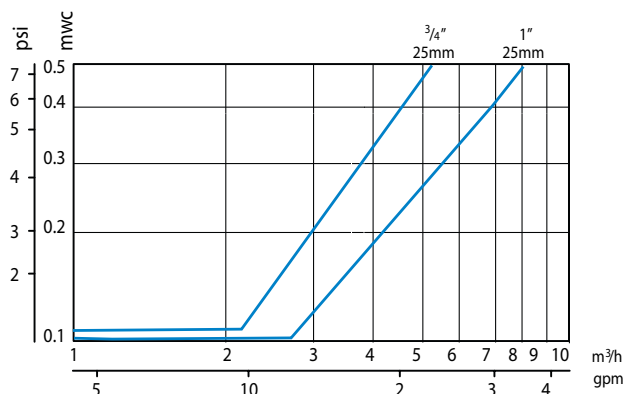

Electrical Specifications

- Standard: 24 VAC 50/60 Hz. ±10%
Optional: other voltage rating or latching DC operators
- Current: 0.25 Amp Inrush; 0.11 Amp holding

Dimensions

Dimension		20mm, 3/4"	25mm, 1"
Height (H)	mm	109	112
	inch	4.3	4.4
Length - Straight (L) Center to outlet-Angle	mm	98	103
	inch	3.9	4.1
Width	mm	75	75
	inch	3	3
Weight	kg	0.28	0.29
	lbs	0.62	0.64

Operation data

		20mm, 3/4"	25mm, 1"
Max. Flow	m³/hr	6	10
	gpm	26	44
Pressure range	bar	0.5-10	
	psi	7-150	
Max. Water Temp.	°C	60	
	°F	140	
Max. Ambient Temp.	°C	52	
	°F	125	

Gal Plastic Valves

Series 75, "GAL" plastic valves are designed for the control of irrigation systems of field crops, vineyards and orchards. The exceptional hydraulic characteristics of the mod.75 enable very high flow rates, at low head losses. Wide range of control functions, allows the design of the irrigation networks to optimal operation.

Features and Benefits

- Structural simplicity
- Superb hydraulic performance
- Reliable control of corrosive liquids
- Light-weight, cost-saving
- Minimum maintenance - maximum dependability

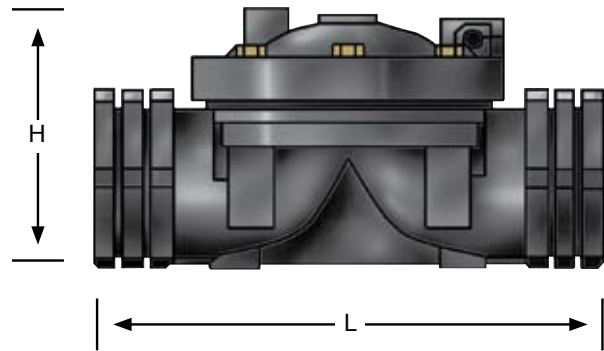

Technical Data

Pressure losses

2-W

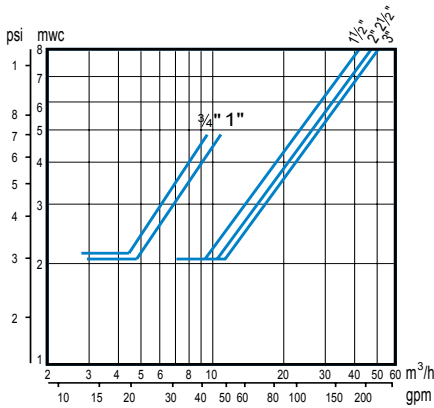

3-W

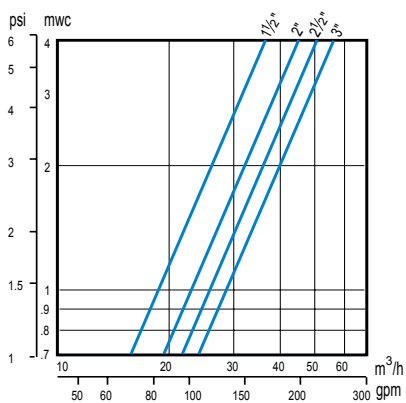

Dimensions

Dimension	20mm, 3/4"	25mm, 1"	35mm, 1 1/2"	50mm, 2"	65mm, 2 1/2"	80mm, 3"	
Height (H)	mm	70	73	110	110	119	120
	inch	2 3/4	2 7/8	4 3/8	4 3/8	4 5/8	4 3/4
Length (L)	mm	113	124	188	199	228	236
	inch	4 1/2	4 7/8	7 3/8	7 7/8	9	9 1/4
Vol.control chamber	cc	36		180			
	gal	0.01		0.05			
Weight	kg	0.2		0.9	1.2	1.4	
	lbs	0.44		2	2.6	3.1	

Operation data

		20mm, 3/4"	25mm, 1"	35mm, 1 1/2"	50mm, 2"	65mm, 2 1/2"	80mm, 3"
Max. Flow	m³/hr	6	10	25	40	65	90
	gpm	26	44	110	176	285	396
Pressure range	bar	1 - 8		1.5 - 10			
	psi	15 - 115		22 - 145			
Max. Water Temp.	°C	60					
	°F	145					

uPVC Valves

The uPVC valves, models 95 (threaded) and 96 (solvent welded directly to the pipe) are made for high-flow irrigation plots and flood tables. The direct- attachment to the PVC pipelines and the optional underground installation, save cost of valve configurations and reduce head losses. Unique diaphragm design generates surge- free closure even at high velocities.

Unique hydrodynamic design allows exceptionally low pressure losses at high flow rates, stable regulation from maximal to near zero flows, surge-free closure and simple, minimal maintenance.

Features and Benefits

- Structural simplicity
- Superb hydraulic performance
- Reliable control of corrosive liquids
- Light-weight, cost-saving
- Minimum maintenance - maximum dependability

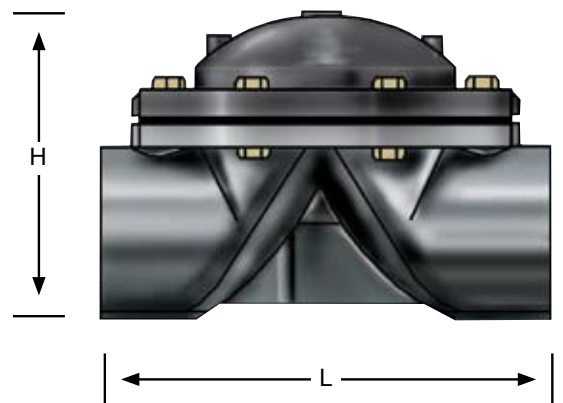

Technical Data

Pressure losses

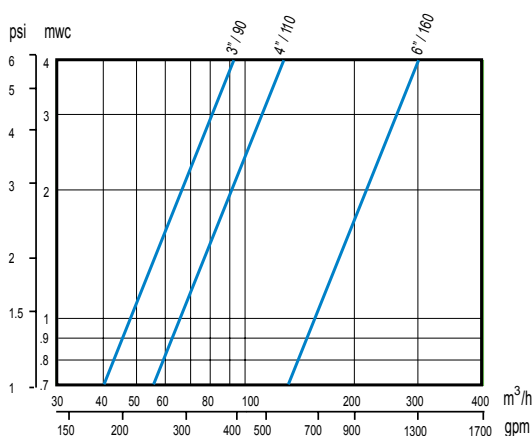

Dimensions

Dimension		90mm, 3"	110mm, 4"	160mm, 6"
Height (H)	mm	195	202	380
	inch	7 ¹¹ / ₁₆	7 ¹⁵ / ₁₆	14 ¹⁵ / ₁₆
Length (L)	mm	258	278	360
	inch	10 ³ / ₁₆	10 ¹⁵ / ₁₆	14 ³ / ₁₆
Vol.control chamber	lit	2.6	2.6	9.9
	gal	0.7	0.7	2.6
Weight	kg	4	4.2	11.8
	lbs	8.8	9.2	26

Operation data

		90mm, 3"	110mm, 4"	160mm, 6"
Max. Flow	m³/hr	90	160	350
	gpm	400	700	1540
Pressure range	bar	0.6 - 8		0.5 - 10
	psi	9 - 115		7 - 145
Max. Water Temp.	°C	40		
	°F	104		

Control functions below are applicable to valve models: 80, 75, 95/96. Pictures are for reference only.

Pressure Reducing Valve

Made to maintain a constant, preset pressure in greenhouses, turf and open field irrigation plots- regardless of pump pressure or demand variations.



2-way Electric Valve

Designed to allow maximal simplicity and reliability in greenhouses and field crop irrigation systems controlled by electronic controller.

Available only in 75 & 80 models.



3-way Electric Valve

Made for high- flow greenhouse irrigation, especially for control of Flood Tables, and of Field crops irrigation networks that are activated by sophisticated controllers.



Pressure Sustaining / Relief Valve

The Sustaining valve maintains a constant, preset pressure in the inlet side, to protect pumps in case of excessive demand. It can also be used to prevent pressure drop in supply pipelines as flow exceeds the designed value, or to discharge excess pressure when installed as a relief valve.



Electrically activated Pressure Reducing Valve

Designed to open and regulate downstream pressure to a stable preset value upon electric command from an irrigation controller. Electric command may be of constant current or pulse, as determined by the controller in use.



Hydraulically activated Pressure Reducing Valve

Designed to open and regulate downstream pressure to a stable preset value upon a hydraulic command delivered through a control tube. This application enables locating all solenoid valves at one convenient point and reduces the risk of lightning strike damages to the system.



Hydraulically Remote Control Valve

The valve will open fully upon a hydraulic command delivered through a control tube. As the pressure is released from the control tube, the valve will be closed drip-tight. This application enables locating all solenoid valves at one convenient point and reduces the risk of lightning strikes damages to the system.



Pressure Reducing / Sustaining Valve

The valve will maintain a preset upstream pressure as well as reduce downstream pressure to required safe value. If upstream pressure is higher than its preset value and downstream pressure is lower than its preset value, the valve will be fully open to allow minimal head losses.



DOROT AUTOMATIC CONTROL VALVES

Founded in 1946, DOROT is a leading developer, manufacturer and marketer of a wide range of superior quality automatic control valves. DOROT's experienced Research & Development Dept. has a long tradition of generating innovative solutions for the application of water control systems. These include, waterworks distribution networks, sewage and effluent disposal, fire protection, mining and irrigation systems.

DOROT's commitment to excellence begins with using the highest quality materials. The company's engineering experts are constantly working to provide customers with a broad range of valve patterns and sizes in a wide variety of metals and grades including: Cast Iron, Ductile Iron, Cast Steel, SST, Bronze, Marine Bronze, Polyamide and P.V.C.

The experts at DOROT custom-design each valve application according to specific control requirements. Most of the production process, which includes machining and coating, takes place in modern in-house facilities. Before leaving the factory, each product is hydraulically tested. An advanced testing laboratory simulates the anticipated field conditions.

With distribution in more than 70 countries world-wide, a key component of the DOROT difference is its outstanding customer service. This includes field assistance, technical advice, training programs and follow-up consultations.

It is all of these factors that make DOROT a leader in fluid control technology and customer satisfaction.

