



300 SERIES

Automatic Hydraulic Control Valves





SERIES 300

Automatic Hydraulic Control Valves

DOROT'S 300 Series is the latest line of state-of-the-art globe type, automatic control valves. This line is designed to withstand even the most demanding water control system requirements. The experts at DOROT developed this technically advanced line with capabilities far beyond any other valve on the market.

Features of the 300 Series:

- The capability to regulate "near zero" flow, completely eliminating the need for a special low flow device (throttling plug) or a low flow bypass valve, while ensuring very low head loss in "fully open" conditions.
- A standard valve model, fit for all control operations. A specific pilot provides the required application.
- The flange (including face-to-face) dimensions suit ISO Standards. This allows for quick and easy replacement of old equipment, without the need for pipeline modifications.



- The valve has an internal floating shaft, allowing for no friction or leakage, eliminating the need for shaft sealing. The unique design of the shaft provides for easy field maintenance.

Everything Is Under Control

- The valve has a resilient seal disc, guided by an almost frictionless centering device.
- The valve's body is made of Ductile Iron, withstanding both high hydraulic and mechanical stresses.
- A standard single chamber valve, enabling jam-free operation in sensitive regulation conditions. If desired, conversion from a single to a double chambered valve is easily accomplished through the insertion of DOROT's innovative separation disc, without the need to remove the valve from the pipeline during the conversion.
- The valve is fabricated with an easily replaceable seat, made of SST. It maintains excellent durability against erosion, ensuring a drip-tight seal.
- During the closing procedure, the pace slows down, preventing damage that may occur from water slam/surge.
- The series includes, as an optional feature, a valve position indicator, attached by a floating connection (ball & socket), resulting in smooth movement, with no wear or tear on the indicator seal.
- All control ports are protected by Stainless - Steel inserts.
- Air release device - easily operated for initial valve commissioning.



Remote Control & Check Valves

EL - Solenoid Controlled Valve

A 3-way solenoid valve, activated by an electric current or an electric pulse, which opens or closes the main valve. The standard valve is supplied in the "normally closed" position. The "normally open" position is optional. Electric activation can be added to other control valves on request.



EL

Pressure Reducing Valves

PR - Pressure Reducing Valve

The valve maintains a preset downstream pressure, regardless of upstream pressure or flow rate fluctuation. The main valve is controlled by either a 3-way pilot valve (allowing full opening when downstream pressure drops below the set-point), or by a 2-way pilot valve (creating a pressure differential in any condition).



PR

PR(D) - Proportional Pressure Reducing Valve

The valve maintains a constant pressure ratio between its upstream and downstream pressure, regardless of upstream pressure or flow rate values. No external control device is needed.



PR[D]

Pressure Sustaining & Relief Valves

PS - Pressure Sustaining Valve

PS(R) - Pressure Relief Valve

The valve maintains upstream pressure, regardless of flow rate variations. The valve will be in the "closed" position if the upstream pressure drops below the set-point and will fully open when the upstream pressure exceeds the set-point.



PS

QR - Quick-Relief Safety Valve

The valve instantly opens when the pressure in the pipeline exceeds the safe level, thus relieving excessive pressure from the network. When the pressure returns to normal, the valve closes slowly, at an adjustable pace.



QR

Flow Rate Control Valves

FR - Flow Rate Control Valve

The valve limits the flow rate in the network to a preset level, regardless of pressure variations. The valve fully opens when the flow rate drops below the set-point.



FR

FE - Excessive Flow Shut-Off Valve

The valve closes when the flow rate exceeds the normal value (due to pipe rupture, for example).
Optional Addition: Surge-Preventing Closure (SP).



FE

Level Control Valves

FL - Float Controlled Valve

The main valve is controlled by a float valve, located in the tank or reservoir and set at the required maximum water level. The valve maintains the maximum level continuously.
Optional Addition: Surge-Preventing Closure (SP).



FL

FLDI 1 /FLDI 2 - Differential Float Controlled Valve

A float valve controls the main valve, closing it when the water reaches maximum level, and opening it when the water drops to its preset minimum level. The differential between the maximum level and the minimum level is adjustable.
Optional Addition: Surge-Preventing Closure (SP).



FLDI

AL - Altitude Control Valve

The main valve is controlled by a highly sensitive pilot, located outside the tank. The pilot opens or closes the valve in response to the static pressure of the water. The pilot allows for differential adjustments between the maximum and minimum level.
Optional Addition: Surge-Preventing Closure (SP).



AL

Pump System Control Valves

NS - Non-slam Check Valve

A dual-stage hydraulic check valve. The closure of the valve takes place at two sequential rates: The first is a rapid closure, preventing large volume return flow. The second is a slow, cushioned closure that eliminates slumming. The travel percentage of the first stage and the speed of closure of the second are adjustable.

BC - Pump Control Valve

The valve eliminates damaging surges caused by pump start-up and shut-off. The electrically activated valve gradually opens on pump start-up, and slowly closes before the pump is switched off. In case of unexpected power failure, The valve operates as a non-slam check valve, preventing reverse flow. Optional Additions: Flow Rate Limitation (FR), Extended Closure (CD), Two-Stage Operating (TO), Reducing (PR) and Sustaining Pressure (PS).

DW - Deep Well Control Valve

The valve eliminates surges caused by the start-up and shut-off of vertical or submersible pumps. It is a relief valve, assembled on a T-junction of the main pipeline. When the pump starts, the valve slowly closes, gradually increasing network pressure. Before pump shut-off, the valve slowly opens, gradually reducing network pressure.

RE - Surge Anticipating Valve

The valve protects the pumping system from water hammer, caused by sudden pump shut-off (from power failure, for example). The valve is a relief valve, assembled on a T-junction of the main pipeline. The valve instantly opens when the pump stops, relieving the returning high pressure wave. The valve slowly closes once the pressure returns to the static level. The valve also functions as a pressure relief valve. Optional Additions: Surge-Preventing Closure (SP).



BC



DW



RE

Special Control Applications

DI - Pressure Differential Sustaining Valve

The valve maintains a preset pressure differential between the upstream and downstream pressures. The valve controls the booster pump discharge, heating and cooling systems, bypass configurations, etc...

EC - Electronically Controlled Valve

The valve is controlled by the versatile "ConDor", a user-friendly controller that enables highly accurate control of all the functions listed above. The "ConDor" enables an unlimited number of control functions such as, time related operation, the batching of liquid, and conditional (automatically modified) control parameters, in various applications.

SP - Surge-Preventing Closure

The device automatically adjusts the closing speed of a valve that is located at the end of a long pipeline. This ensures a pace that prevents pressure surges. Please consult DOROT for more details.



DI



EC

Dimensions & Weights

Globe Flanged Type

Valve Size	50 (2")		65 (2½")		80 (3")		100 (4")		150 (6")		200 (8")		250 (10")	
	mm	inch	mm	inch	mm	inch	mm	inch	mm	inch	mm	inch	mm	inch
L	230	9 ¹ / ₁₆	292	12 ¹ / ₂	310	12 ³ / ₁₆	350	13 ³ / ₄	480	18 ⁷ / ₈	600	23 ¹ / ₁₆	730	28 ³ / ₄
H	185	7 ⁵ / ₁₆	185	7 ⁵ / ₁₆	230	9 ¹ / ₁₆	240	8 ⁷ / ₁₆	330	13	390	15 ³ / ₈	520	20 ¹ / ₂
h**	140	5 ¹ / ₂	140	1 ¹ / ₁₆	170	1 ¹ / ₈	180	7	230	9	270	11	350	13 ³ / ₄
W	170	6 ¹¹ / ₁₆	170	6 ¹¹ / ₁₆	200	7 ⁷ / ₈	235	9 ¹ / ₄	330	13	415	16 ³ / ₁₆	525	20 ¹¹ / ₁₆
R	82.5	3 ¹ / ₄	92.5	3 ⁵ / ₈	100	3 ¹⁵ / ₁₆	110	4 ⁵ / ₁₆	142.5	5 ⁵ / ₈	172.5	6 ³ / ₄	205	8 ¹ / ₁₆
Weight Kg/lbs*	12 / 26		13 / 29		22 / 49		37 / 82		80 / 176		157 / 346		245 / 540	
Vol. control chamber lit/gal	0.1 / 0.02		0.1 / 0.02		0.3 / 0.08		0.7 / 0.2		1.5 / 1.4		4.3 / 1.1		9.7 / 2.6	
Valve Size	300 (12")		350 (14")		400 (16")		450 (18")		500 (20")		600 (24")		700 (28")	
	mm	inch	mm	inch	mm	inch	mm	inch	mm	inch	mm	inch	mm	inch
L	850	33 ⁷ / ₁₆	980	38 ⁹ / ₁₆	1100	43 ⁵ / ₁₆	1200	47 ¹ / ₄	1250	49 ³ / ₁₆	1450	57 ¹ / ₁₆	1650	64 ¹⁵ / ₁₆
H	635	25	635	25	855	33 ⁵ / ₈	855	33 ⁵ / ₈	855	33 ⁵ / ₈	1120	44 ¹ / ₈	1310	44 ¹ / ₈
h**	1450	57	1500	59	1410	55 ¹ / ₂	1420	56	1450	57	1130	44 ¹ / ₂	160	53 ¹ / ₄
W	610	24	610	24	850	33 ⁷ / ₁₆	850	33 ⁷ / ₁₆	850	33 ⁷ / ₁₆	1100	43 ⁹ / ₁₆	1100	43 ⁹ / ₁₆
R	230	9	260	10 ³ / ₁₆	290	11 ³ / ₈	310	12 ³ / ₁₆	357.5	14 ¹ / ₁₆	420	16 ¹ / ₂	455	17 ⁷ / ₈
Weight Kg/lbs*	405 / 893		510 / 1124		822 / 1812		945 / 2083		980 / 2160		1950 / 4299		4740 / 5291	
Vol. control chamber lit/gal	18.6 / 4.9		18.6 / 4.9		50 / 13.2		50 / 13.2		50 / 13.2		84 / 22.2		84 / 22.2	

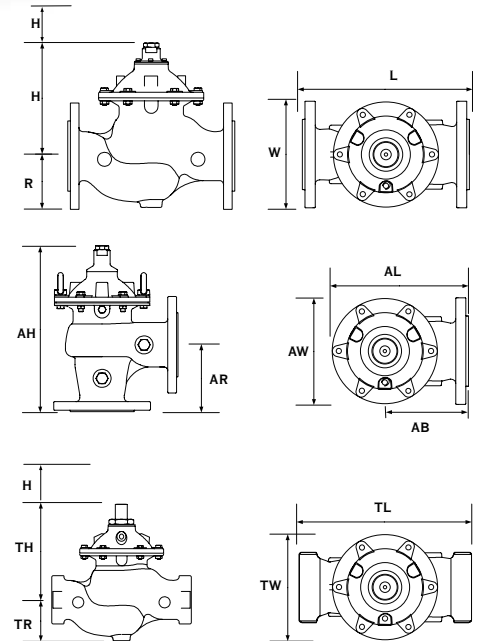

Angle Type

Valve Size	50 (2")		80 (3")		100 (4")		150 (6")		200 (8")	
	mm	inch	mm	inch	mm	inch	mm	inch	mm	inch
AL	208	8 ³ / ₁₆	250	9 ¹³ / ₁₆	295	11 ¹ / ₁₆	405	16	505	19 ⁷ / ₈
AH	240	9 ⁷ / ₁₆	415	16 ⁵ / ₁₆	445	17 ¹ / ₂	570	22 ⁷ / ₁₆	635	25
AW	170	6 ¹¹ / ₁₆	200	7 ⁷ / ₈	235	9 ¹ / ₄	330	13	415	16 ⁵ / ₁₆
AR	107	4 ³ / ₁₆	138	5 ⁷ / ₁₆	147	5 ¹³ / ₁₆	180	7 ¹ / ₁₆	302	11 ⁷ / ₈
AB	125	4 ¹⁵ / ₁₆	150	5 ⁷ / ₈	173	6 ¹³ / ₁₆	240	9 ⁷ / ₁₆	300	11 ¹³ / ₁₆
Weight Kg/lbs*	12 / 26		20 / 44		37 / 81		76 / 167		150 / 330	

Globe Threaded Type

Valve Size	40 (1½")		50 (3")	
	mm	inch	mm	inch
TL	215	8 ⁷ / ₁₆	215	8 ⁷ / ₁₆
TH	185	7 ⁵ / ₁₆	185	7 ⁵ / ₁₆
h**	140	5 ¹ / ₂	140	5 ¹ / ₂
TW	129	5	129	5
TR	62	2 ³ / ₈	62	2 ³ / ₈
Weight Kg/lbs*	7 / 15		7 / 15	

*Approximate shipping Weight (PN 25)

** h = Minimal required maintenance space

End Connections (for PN16 or PN25)

ISO 2084,2441,5752 ANSI B16,AS2129,JIS B22.

Size Selection Table

Valve	40 (1½")	50 (2")	65 (2½")	80 (3")	100 (4")	150 (6")	200 (8")	250 (10")	300 (12")	350 (14")	400 (16")	450 (18")	500 (20")	600 (24")	700 (28")	
Max. recommended flow rate for continuous operation (m ³ /h - V = 5.5m/s)	25	40	40	90	160	350	480	970	1400	1900	2500	3100	3900	5600	7600	
Max. recommended flow rate for continuous operation (Gpm - V = 18f/s)	110	180	180	400	700	1600	2800	4300	6200	8400	11000	17000	17000	24700	33500	
Min. recommended flow rate	<1m ³ /h (<5 gpm)															
Globe Type																
Flow Rate Factor:	Kv (Metric)	43	43	43	103	167	407	676	1160	1600	1600	3300	3300	3300	7000	7000
	Cv (US)	50	50	50	120	195	475	790	1360	1900	1900	3860	3860	3860	8200	8200
Head Loss Factor K (dimensionless)	2.2	5.4	15.4	6.7	5.6	4.8	5.5	4.5	5	9	3.8	6	5.9	4.3	7.8	
Angle Type																
Flow Rate Factor:	Kv (Metric)	60	60		140	190	460	770								
	Cv (US)	70	70		164	222	537	900								
Head Loss Factor K (dimensionless)	1.3	2.8		3.3	4.3	4.3	4.2									

For head Loss of fully open valves use the following equations:

$$H(\text{Bar}) = \left(\frac{Q[\text{m}^3/\text{h}]}{K_v} \right)^2 \quad H(\text{Psi}) = \left(\frac{Q[\text{gpm}]}{C_v} \right)^2 \quad H = K \frac{V^2}{2g}$$

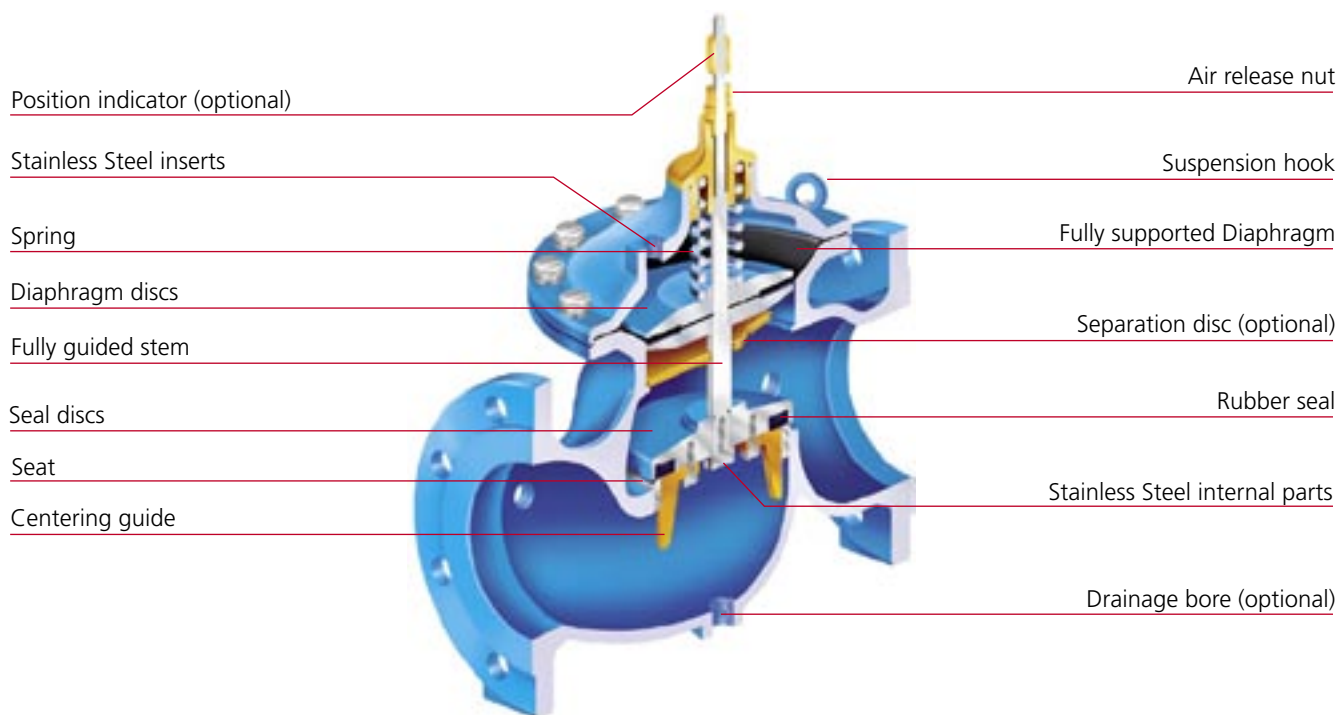

Materials

Main Valve

Components	Materials	Options
Body & Bonnet	Ductile Iron	Bronze, Marine Bronze, Cast Steel
Top Stem Guide	Bronze	SST
Stem	SST	
Diaphragm Discs	SST	Cast Steel
Seal Disc	SST	Cast Steel
Diaphragm	Reinforced NBR	EPDM
Seal	EPDM Rubber	
Inserts	SST	

Components	Materials	Options
Seat	SST	
Centering Guide	Bronze	SST
Indicating Rod	SST	
Indicator Guide	Brass	SST
Bolts & Nuts	SST	
Spring	SST	
Separation Disc	Bronze/SST	
Coating	Polyester	Fusion Bonded Epoxy, Nylon 11- Risan <i>Others on request</i>

How To Order

Please specify the requested valve in the following sequence (see example below):

Model	Size	Connection Standard	Control Applications	Additional Features	Special Instructions
30 / 31 / [D]	(Inch): 1 1/2" -28"	ISO, ANSI, JIS, etc.		Check Valve	
30	6	ISO PN16	EL	CV	Bronze Body

For more details on ordering refer to the price list.

DOROT AUTOMATIC CONTROL VALVES

Founded in 1946, DOROT is a leading developer, manufacturer, and marketer of a wide range of superior quality control valves. DOROT's experienced Research & Development Dept. has a long tradition of generating innovative solutions for the application of water control systems. These include: waterworks distribution networks, sewage and effluent disposal, fire protection, mining, and irrigation systems.

DOROT's commitment to excellence begins with using the highest quality materials. The company's engineering experts are constantly working to provide customers with a broad range of valve patterns and sizes in a wide variety of metals and grades including: Cast Iron, Ductile Iron, Cast Steel, SST, Bronze, Marine Bronze, Polyamide and P.V.C.

The experts at DOROT custom-design each valve application according to specific control requirements. Most of the production process, which includes, machining, and coating, takes place in modern in-house facilities.

Before leaving the factory, each product is hydraulically tested. An advanced testing laboratory simulates the anticipated field conditions.

With distribution in more than 70 countries world-wide, a key component of the DOROT difference is its outstanding customer service. This includes field assistance, technical advice, training programs and follow-up consultations.

It is all of these factors that make DOROT a leader in fluid control technology and customer satisfaction.

